

# QEF 75 Flat Blade Louvre Data Sheet

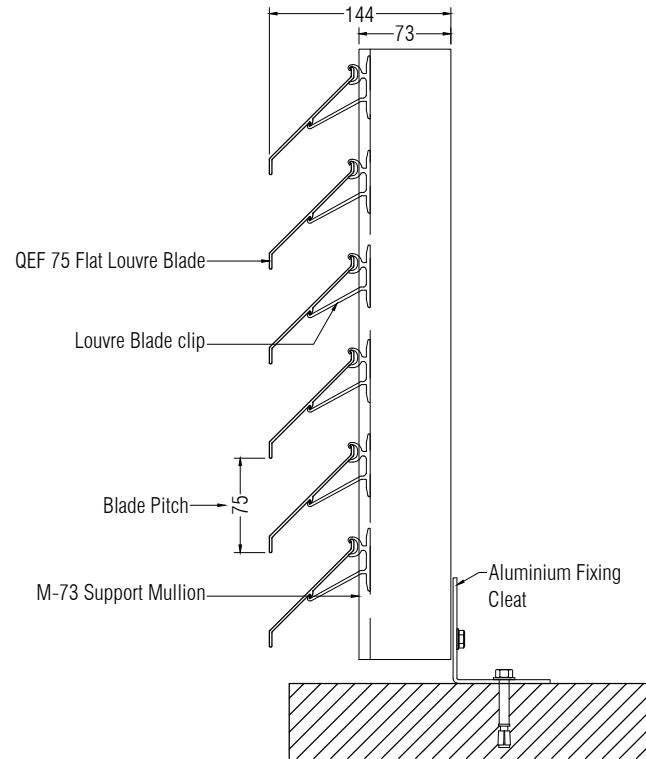

Section of Blades & Mullion

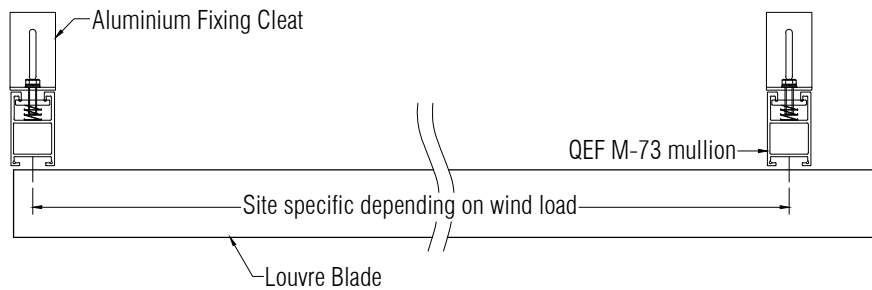

Plan Detail

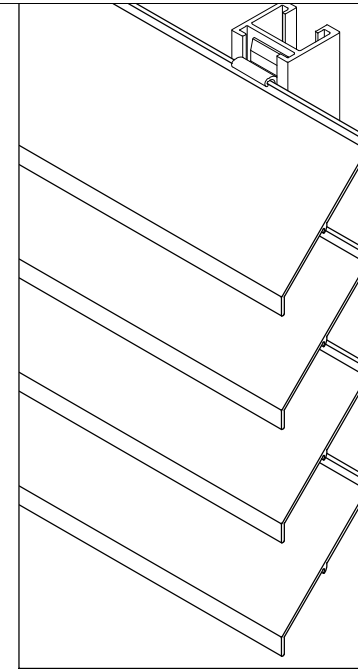

Isometric Detail

## Specification

**Manufacture & Reference:** QEF 75F Louvre System, supplied and installed by QEF Ltd.  
 Tel: +353 (0)56 776 4910  
 Email: enquiries@qeftd.ie

**Description:** 75mm Flat ventilation louvre, mounted on mullions fixed to structure with grade A4 stainless steel fasteners and adjustable galvanised steel cleats.

**Blade pitch:** 75mm.

**Material:** Manufactured from extruded aluminium alloy 6063 T6.

**Finish:** Polyester powder coated to RAL or BS colour, in matt, satin or gloss finishes

**Dimensions:** All Louvres are bespoke to clients needs

**Performance:** Nominal Free Area: 57%

**Fixing:** Mullion spacing and fixing centres to rear steel (by others) subject to site wind loads and independent engineering.

**Accessories:** Single / Double doors.



Commercial Centre, Dublin  
 Road, Kilkenny, R95 TR82,  
 Ireland

Tel: +353 (0)56 776 4910  
 Website: www.qeftd.ie  
 Email: sales@qeftd.ie

Drawn:	RAB	Date:	02/03/2023	Scale:	NTS
Dwg.No:	L/75F/S/H/M73/NC	Rev:			A