

QEF AC300 DOUBLE BANK ACOUSTIC LOUVRE M/C

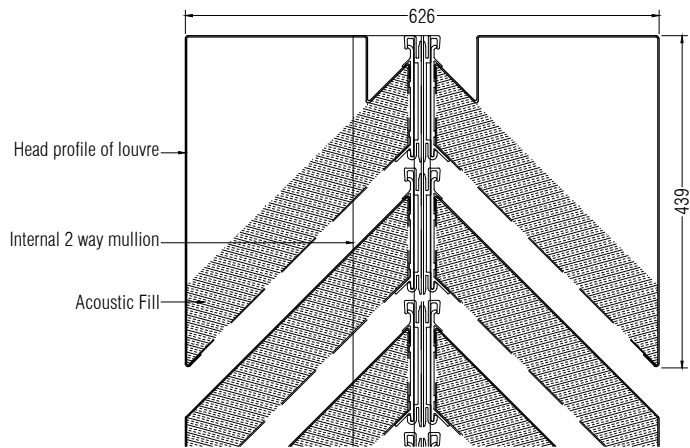

QEF AC300 D/B Louvre
Head Detail

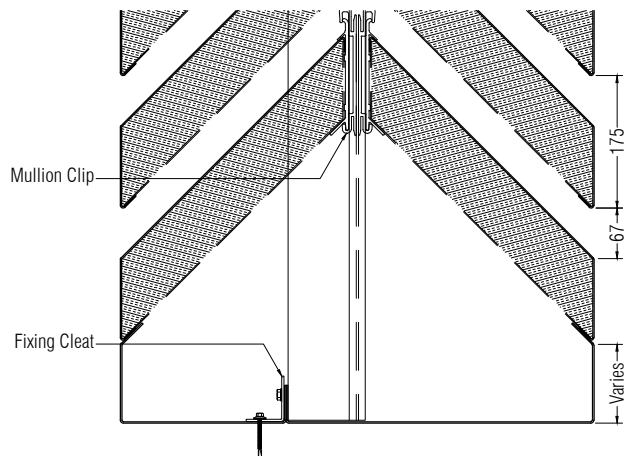

QEF AC300 D/B Louvre
Base Details

Acoustic Performance to BS EN ISO 10140-2:2010.
SRL Test Report No: C/23553/T01

Octave Band Centre Frequency (Hz)	63	125	250	500	1k	2k	4k	8k
Transmission Loss (dB)	11.4	11.8	15.1	23.6	34.1	39.9	36.1	30.8
Acoustic Rating	Rw 28 dB							

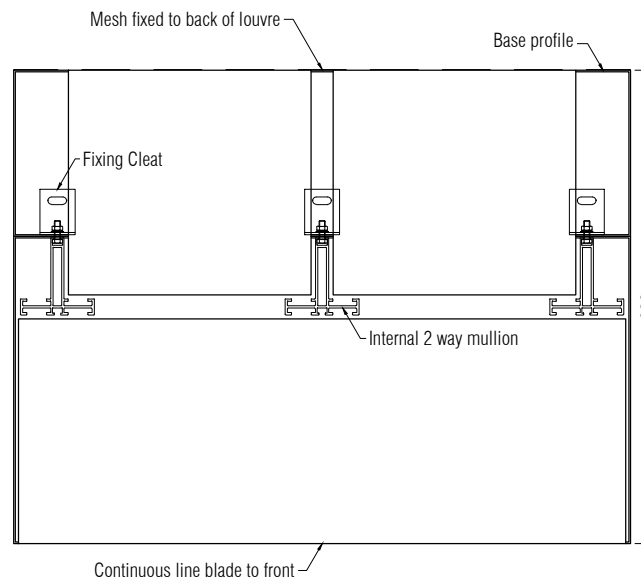

QEF AC300 D/B Louvre
Plan view

Specification

Manufacture & Reference: QEF AC300 Double Bank Acoustic Louvre System, supplied and installed by QEF Ltd.
Tel: +353 (0)56 776 4910
Fax: +353 (0)56 776 1557.

Description: Double bank acoustic louvre with casement surround, mullion/clip format, fixed to structure with adjustable galvanised steel or S/S cleats.

Blade pitch: 175mm

Material: Available in aluminium, galvanised steel & colorcoat steel.

Acoustic Fill: Polyester Fibre.

Finish: Polyester powder coated to RAL or BS colour, in matt, satin or gloss finishes

Dimensions: All Louvres are bespoke to clients needs

Performance: Acoustic performance as per table.

Fixing: All structural support by main contractor

Accessories: Bird / insect mesh, blanking / insulated blanking plate to rear. Single / Double doors.



Commercial Centre
Dublin Road
Kilkenny

Tel: +353 (0)56 776 4910
Fax: +353 (0)56 776 1557
Website: www.qefltd.ie
Email: sales@qefltd.ie

Drawn:	Date:	Scale:
TB	30/01/17	NTS
Dwg.No:	Rev:	
AC300 DB/MC		