

QEF 50HP PROFILE CURVED BLADE

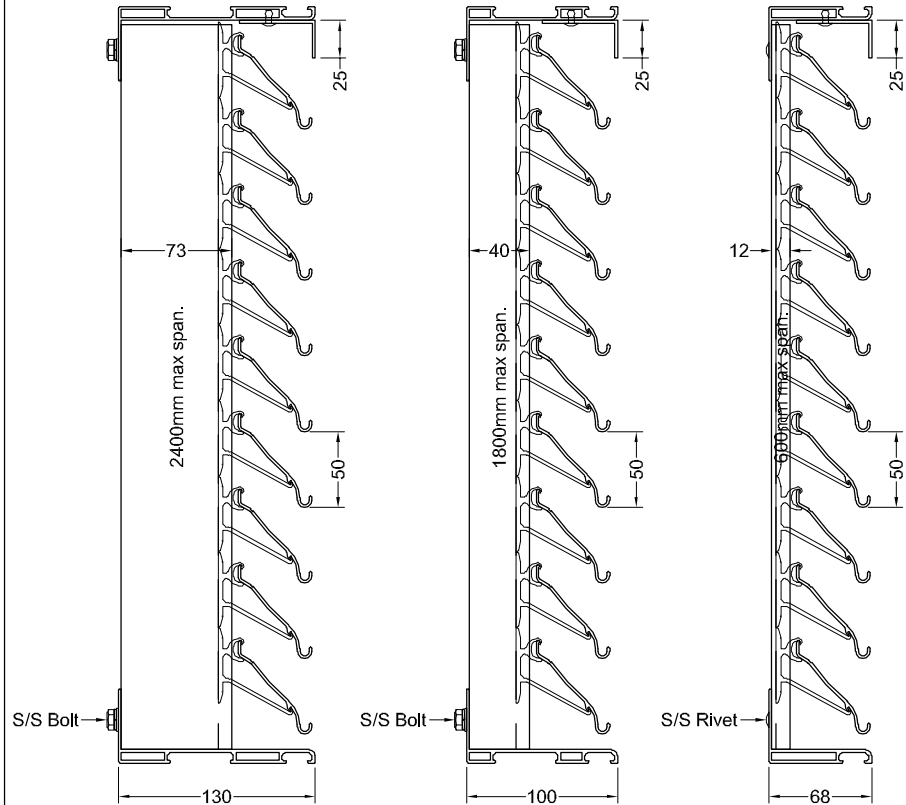

QEF 50HP Profile Louvre with Long Span Mullion

QEF 50HP Profile Louvre with Standard Mullion

QEF 50HP Profile Louvre with Slim Mullion

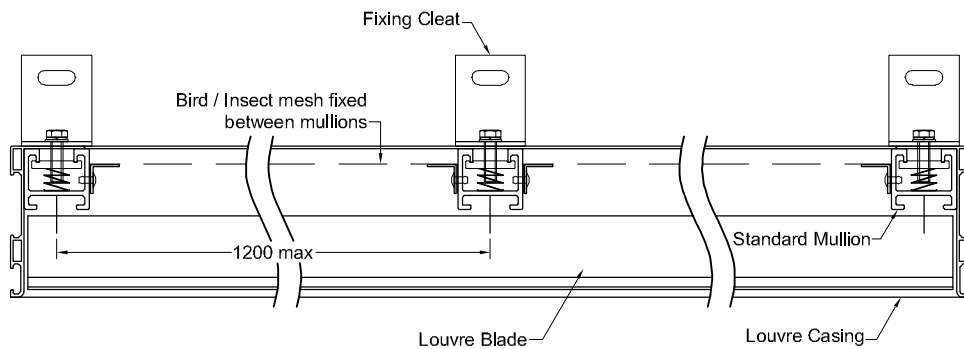
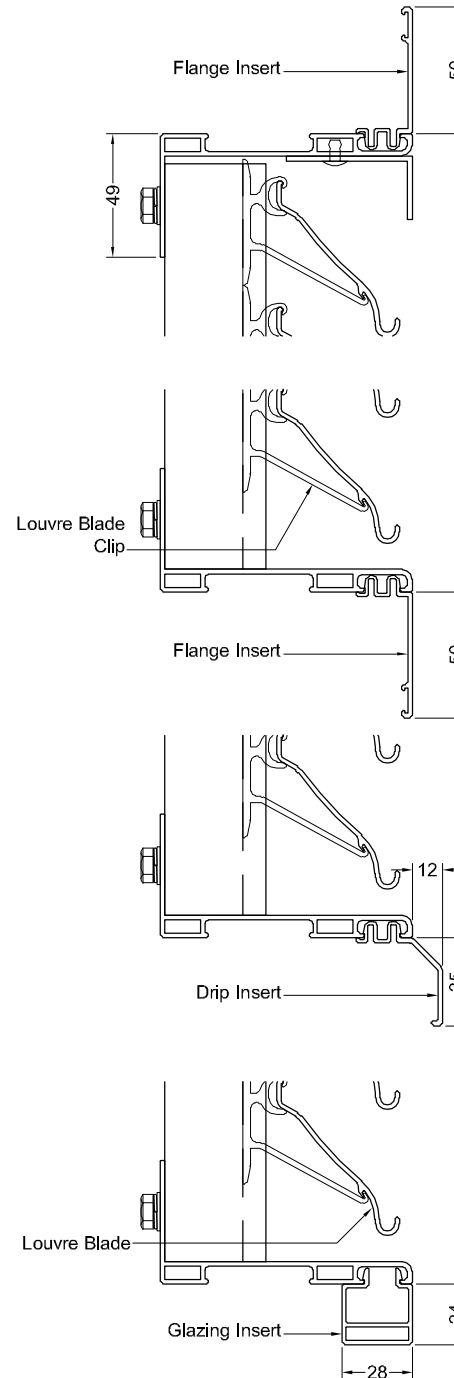

Specification

Manufacture & Reference: QEF 50HP Profile Louvre System, supplied and installed by QEF Ltd.
Tel: +353 (0)56 776 4910
Fax: +353 (0)56 776 1557.

Description: 50mm Curved single bank ventilation Louvre to match profile of QEF High Performance blade with casement surround, mounted on mullions fixed to structure with adjustable galvanised steel cleats.

Blade pitch: 50mm.

Material: Manufactured from extruded aluminium alloy 6063 T6.

Finish: Polyester powder coated to RAL or BS colour, in matt, satin or gloss finishes

Dimensions: All Louvres are bespoke to clients needs

Fixing: All structural support by main contractor

Accessories: Bird / insect mesh, blanking / insulated blanking plate to rear. Single / Double doors.



Commercial Centre
Dublin Road
Kilkenny

Tel: +353 (0)56 776 4910
Fax: +353 (0)56 776 1557
Website: www.qefltd.ie
Email: sales@qefltd.ie

| | | |
|--------------|----------|--------|
| Drawn: | Date: | Scale: |
| RAB | 14/04/16 | NTS |
| Drawn No: | Rev: | |
| L/50HP.P/S/H | A | |