

QEF 90 Screening Blade Data Sheet

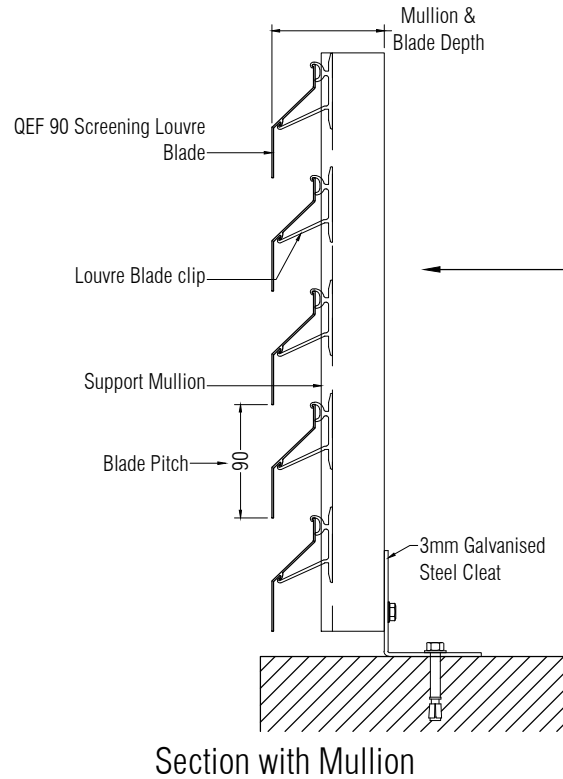

Depth Table for Louvres

90S Louvre Depth		
Mullion Type	Depth with Mullion	Casing Depth
12-M	51mm	68mm
40-M	79mm	100mm
50-M	89mm	100mm
73-M	112mm	130mm

50-M used as standard and shown in section. Contact QEF to discuss site specific mullion & blade spans.

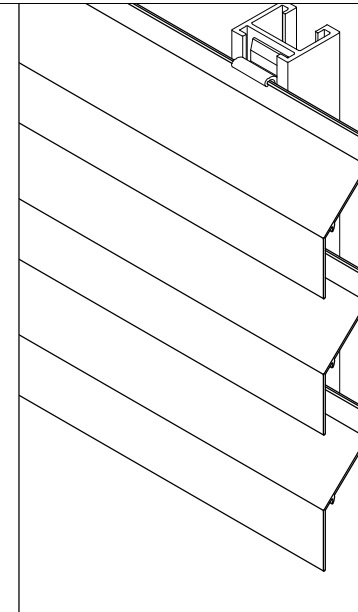

Isometric Detail

Casing Insert Options where Casings are requested

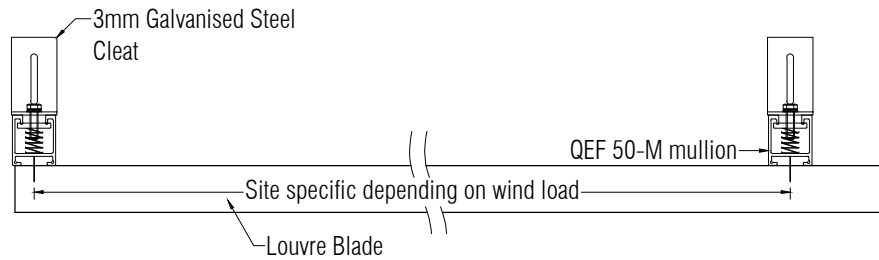
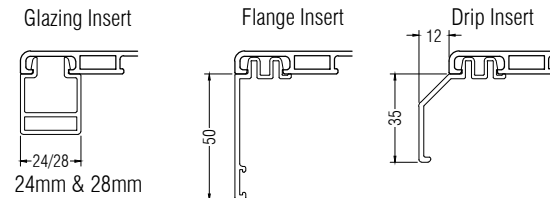

Specification

Manufacture & Reference: QEF 90 Screening Blade Louvre System, supplied and installed by QEF Ltd.
Tel: +353 (0)56 776 4910
Email:sales@qeftd.ie

Description: 90mm Flat ventilation Louvre with 40mm flat face and casement surround, mounted on mullions fixed to structure with adjustable galvanised steel cleats.

Blade pitch: 90mm.

Material: Manufactured from extruded aluminium alloy 6063 T6.

Finish: Polyester powder coated to RAL or BS colour, in matt, satin or gloss finishes

Dimensions: All Louvres are bespoke to clients needs

Performance: Louvre is not weather tested. Nominal free area: 34%

Fixing: Mullion spacing and fixing centres to rear steel (by others) subject to site wind loads and independent engineering.

Accessories: Perimeter Casings, bird / insect mesh, blanking / insulated blanking plate to rear. Single / Double doors.



Commercial Centre, Dublin Road, Kilkenny, R95 TR82, Ireland
Tel: +353 (0)56 776 4910
Website: www.qeftd.ie
Email: sales@qeftd.ie

Drawn: RAB	Date: 13/03/2019	Scale: NTS
Dwg.No: L/90/S/H	Rev: B	