

# QEF 350 AEROFOIL STR END PLATE BRISE SOLEIL

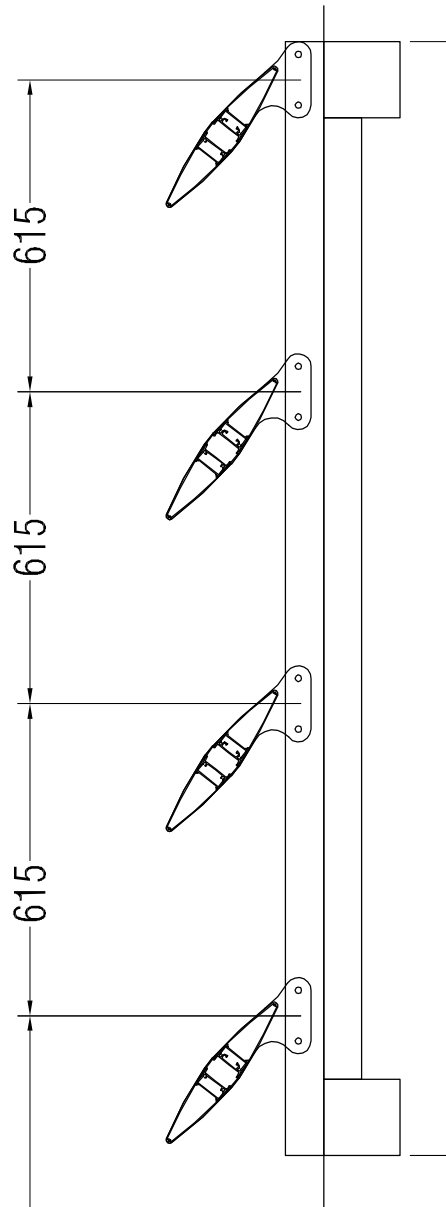

TYPICAL SECTION DETAILS

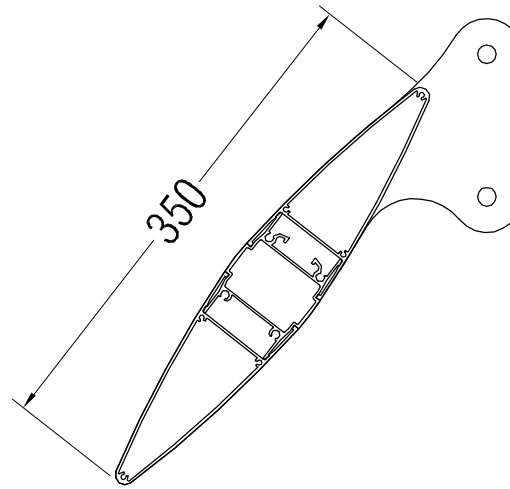

STRUCTURAL END PLATE DETAIL

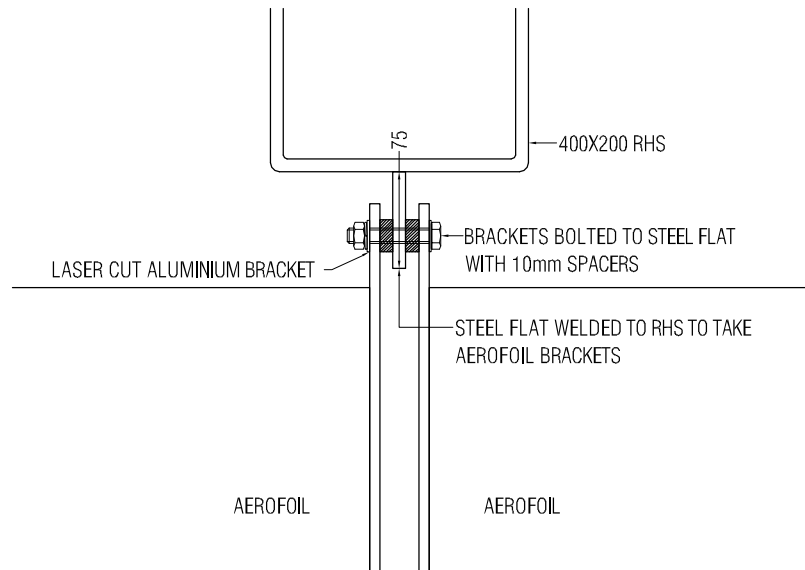

PLAN DETAIL OF AEROFOIL CONNECTION

## Specification

**Manufacturer and reference:** QEF 350  
Aerofoil Brise Soleil system supplied and installed by QEF Ltd.  
Tel: +353 (0)56 776 4910  
Fax: +353 (0)56 776 1557.

**Description:** Extruded Aluminium Aerofoil, 350mm wide fixed with structural end plates.

**Blade Pitch:** To clients specification.

**Material:** System manufactured from extruded aluminium alloy 6063 T6.

**Finish:** Polyester powder coated to RAL or BS colour.

**Dimensions:** As shown on drawings. Max span between support arms dependant upon loading requirements. Bespoke side support arm profiles and blade orientation can be contract specific - customer must specify requirement.

**Fixing:** To subcontractors details. A wide range of stainless, galvanised steel or aluminium fixing brackets is available for different fixing grounds, including steel, block & curtain walling.



Commercial Centre  
Dublin Road  
Kilkenny

Tel: +353 (0)56 776 4910  
Fax: +353 (0)56 776 1557  
Website: www.qefltd.ie  
Email: sales@qefltd.ie

Drawn:	Date:	Scale:
RAB	14/04/16	NTS
Drawn:	Rev:	
A350/V/SEP		