

QEF 350 AEROFOIL MULLION/ BRKT BRISE SOLEIL

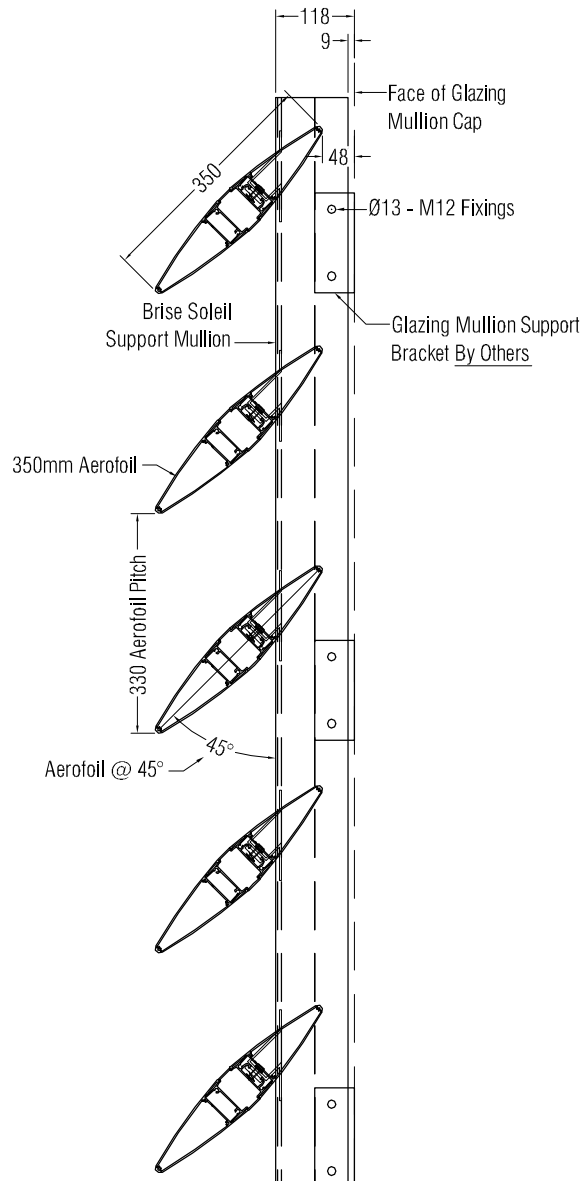

TYPICAL SECTION DETAILS

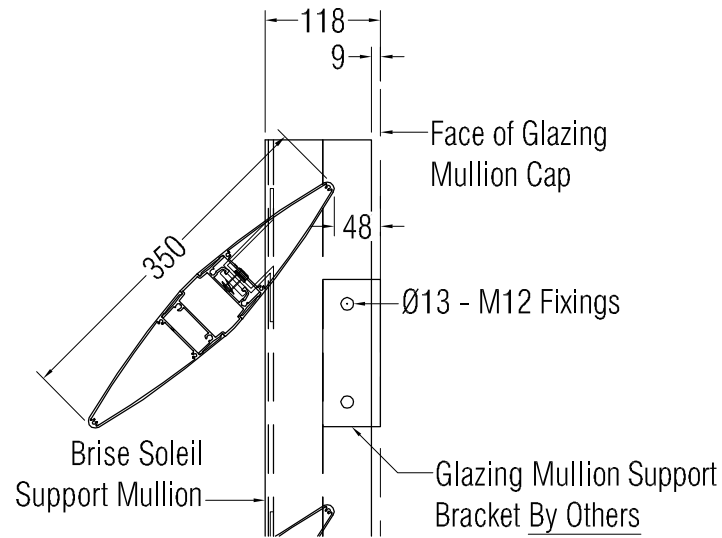

AEROFOIL MULLION CONNECTION

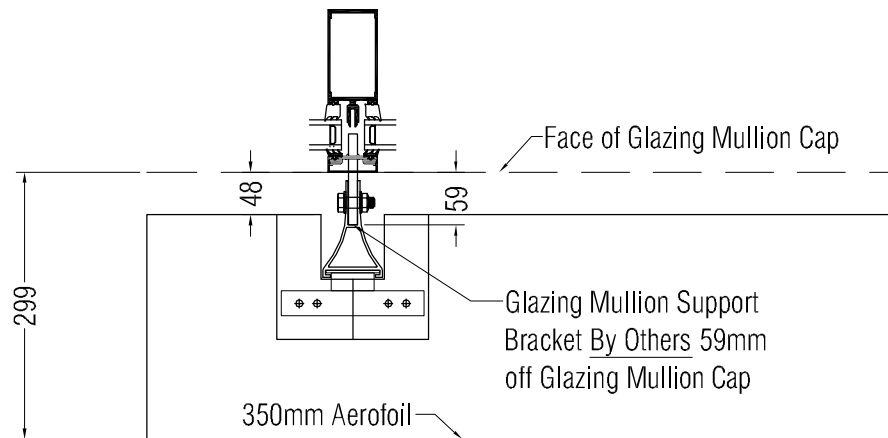

PLAN DETAIL OF AEROFOIL CONNECTION

Specification

Manufacturer and reference: QEF 350
 Aerofoil Brise Soleil system supplied and installed by QEF Ltd.
 Tel: +353 (0)56 776 4910
 Fax: +353 (0)56 776 1557.

Description: Extruded Aluminium Aerofoil, 350mm wide mounted on mullion bracket system.

Blade Pitch: To clients specification.

Material: System manufactured from extruded aluminium alloy 6063 T6.

Finish: Polyester powder coated to RAL or BS colour.

Dimensions: As shown on drawings. Max span between mullions dependant upon loading requirements. Bespoke blade orientation can be contract specific - customer must specify requirement.

Fixing: To subcontractors details. A wide range of stainless, galvanised steel or aluminium fixing brackets is available for different fixing grounds, including steel, block & curtain walling.



Commercial Centre
 Dublin Road
 Kilkenny
 Tel: +353 (0)56 776 4910
 Fax: +353 (0)56 776 1557
 Website: www.qefltd.ie
 Email: sales@qefltd.ie

Drawn:	RAB	Date:	14/04/16	Scale:	NTS
Drawn No.:	A350/V/M/BRKT			Rev:	