

QEF 200 AEROFOIL VERTICAL M/C BRISE SOLEIL @ 45Deg

AEROFOIL BLADE PITCHED AT 350mm CENTRES
TO PREVENT INGRESS OF SUNLIGHT TO A
MAXIMUM ANGLE OF 62° FROM THE HORIZONTAL

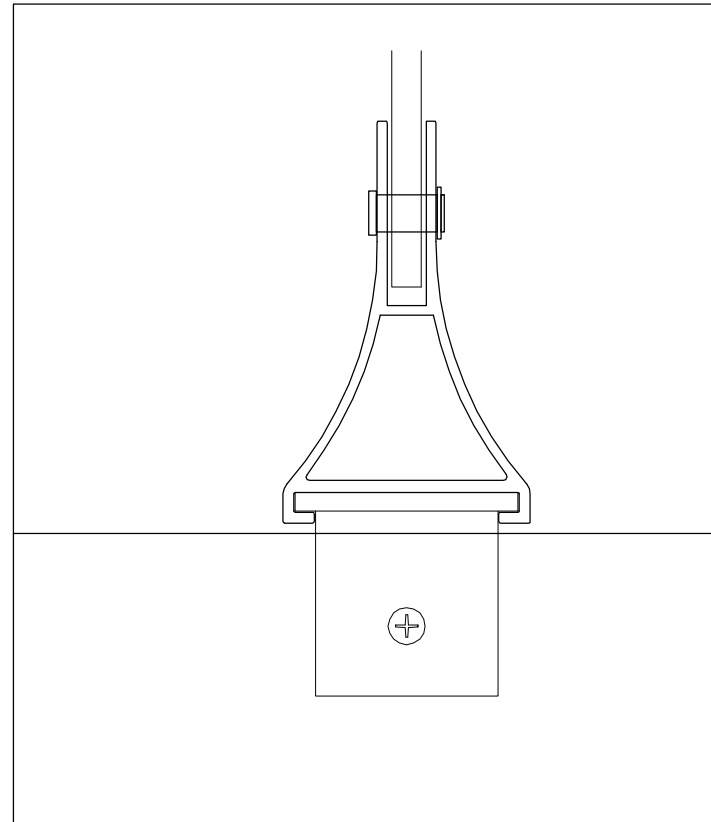
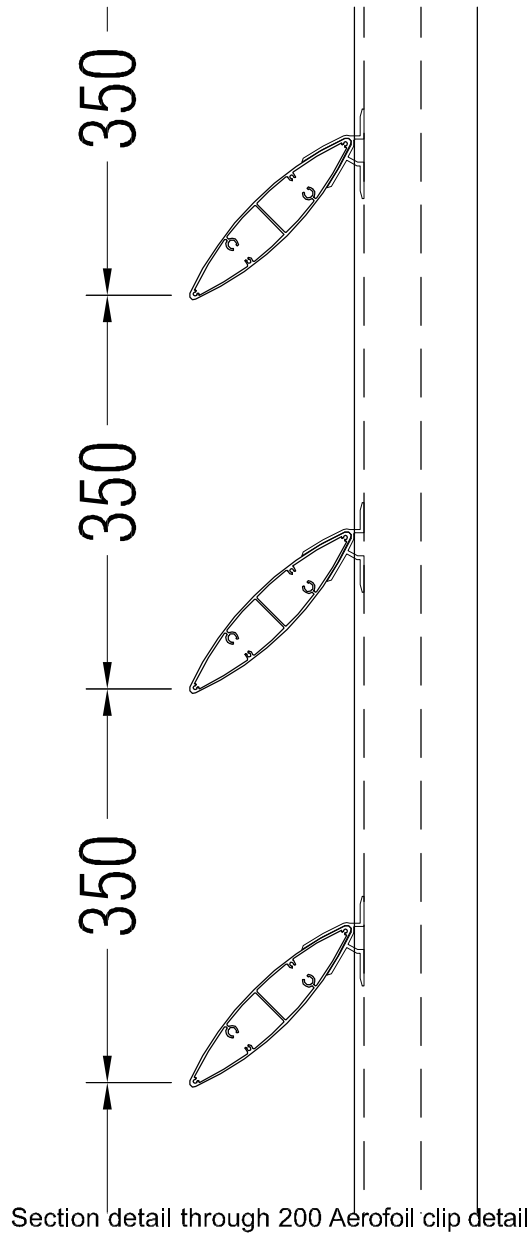

Plan View Mullion / Clip

Specification

Manufacturer and reference: QEF 200 Aerofoil Vertical Mullion/ Clip Brise Soleil system is supplied and installed by QEF Ltd.
Tel: +353 (0)56 776 4910
Fax: +353 (0)56 776 1557.

Description: Extruded Aluminium Aerofoil, 200mm wide mounted on vertical mullion clip system
Blade Pitch: 350mm @ 45° angle.

Material: System manufactured from extruded aluminium alloy 6063 T6.

Finish: Polyester powder coated to RAL or BS colour.

Dimensions: As shown on drawings. Max span between mullions dependant upon loading requirements. Blade orientation and pitch to be contract specific - customer must specify requirement.

Performance: Direct sunlight to be eliminated through the Brise Soleil up to 62°.

Fixing: To subcontractors details. A wide range of stainless, galvanised steel or aluminium fixing brackets is available for different fixing grounds, including steel, block & curtain walling.



Commercial Centre
Dublin Road
Kilkenny

Tel: +353 (0)56 776 4910
Fax: +353 (0)56 776 1557
Website: www.qefltd.ie
Email: sales@qefltd.ie

Drawn	TB	Date	14/04/16	Scale	NTS
Drawn	A200/V/MC/45Deg			Rev	A