

# QEF 140 Screening Blade Data Sheet

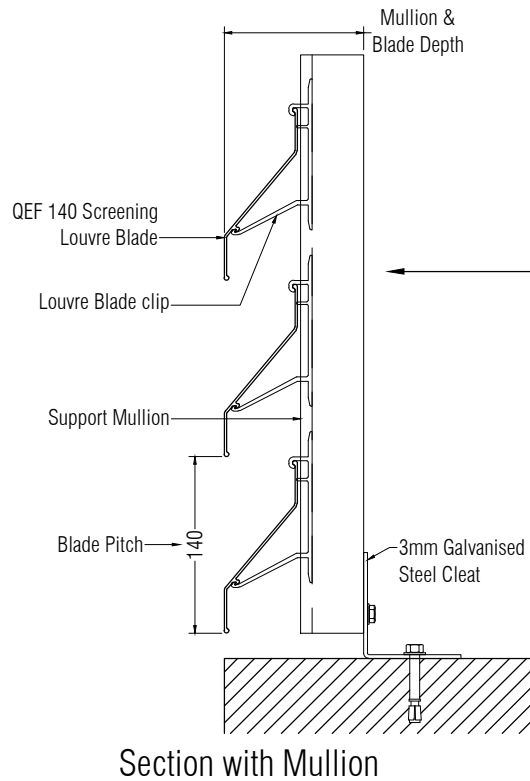

Depth Table for Louvres

140S Louvre Depth		
Mullion Type	Depth with Mullion	Casing Depth
12-M	73mm	100mm
40-M	101mm	100mm
50-M	111mm	130mm
73-M	134mm	155mm

50-M used as standard and shown in section. Contact QEF to discuss site specific mullion & blade spans.

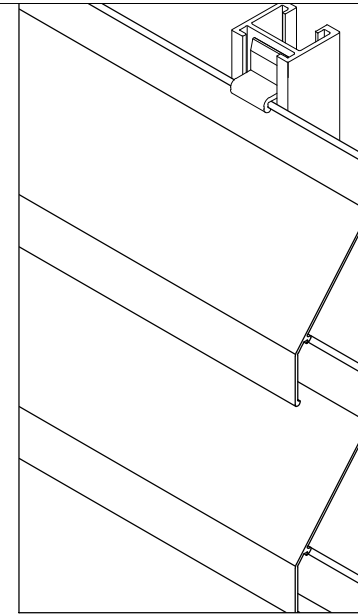

Isometric Detail

## Casing Insert Options where Casings are requested

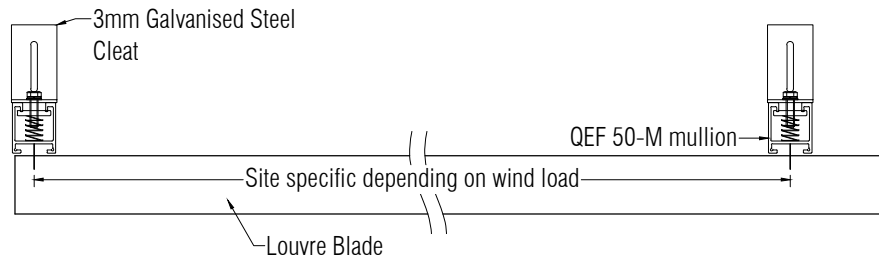
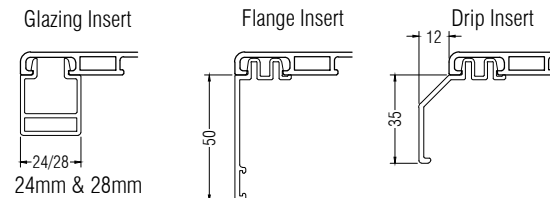

Plan Detail

## Specification

**Manufacture & Reference:** QEF 140 Screening Blade Louvre System, supplied and installed by QEF Ltd.  
Tel: +353 (0)56 776 4910  
Email:sales@qeftd.ie

**Description:** 140mm Flat ventilation Louvre with optional casement surround, mounted on mullions fixed to structure with adjustable galvanised steel cleats.

**Blade pitch:** 120mm to 160mm.

**Material:** Manufactured from extruded aluminium alloy 6063 T6.

**Finish:** Polyester powder coated to RAL or BS colour, in matt, satin or gloss finishes

**Dimensions:** All Louvres are bespoke to clients needs

**Performance:** Louvre is not weather tested. Nominal free area: 35%

**Fixing:** Mullion spacing and fixing centres to rear steel (by others) subject to site wind loads and independent engineering.

**Accessories:** Perimeter Casings, bird / insect mesh, blanking / insulated blanking plate to rear. Single / Double doors.



Commercial Centre, Dublin Road, Kilkenny, R95 TR82, Ireland  
Tel: +353 (0)56 776 4910  
Website: www.qeftd.ie  
Email: sales@qeftd.ie

Drawn: RAB	Date: 29/03/2019	Scale: NTS
Dwg.No: L/140/S/H	Rev: B	