

QEF - Anti- Vandal Galv Screen

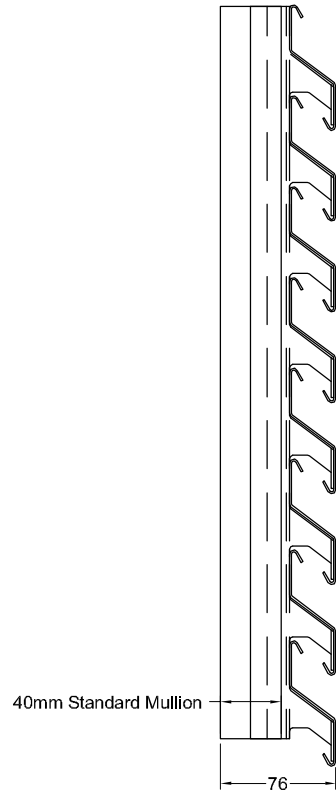

QEF - Galv Louvre
Fixed to Standard Mullion

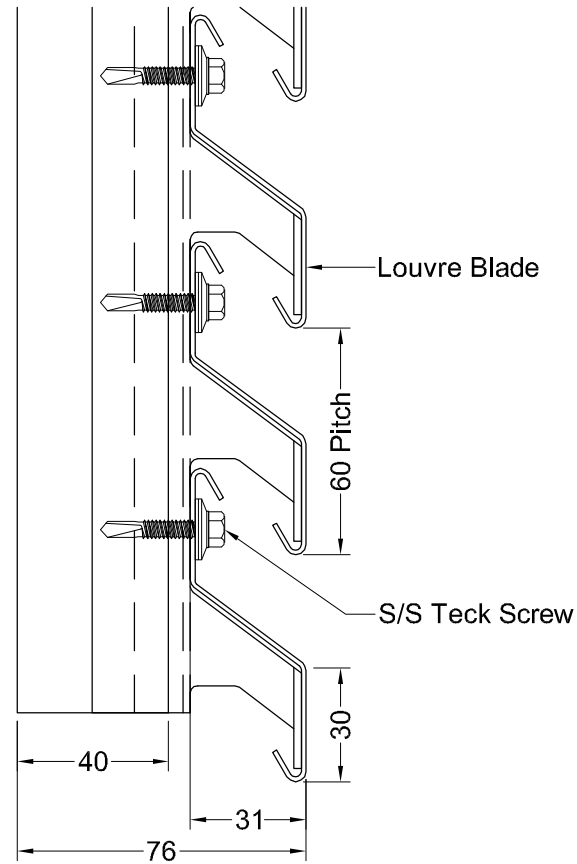

QEF - Galv Louvre
Fixed Details

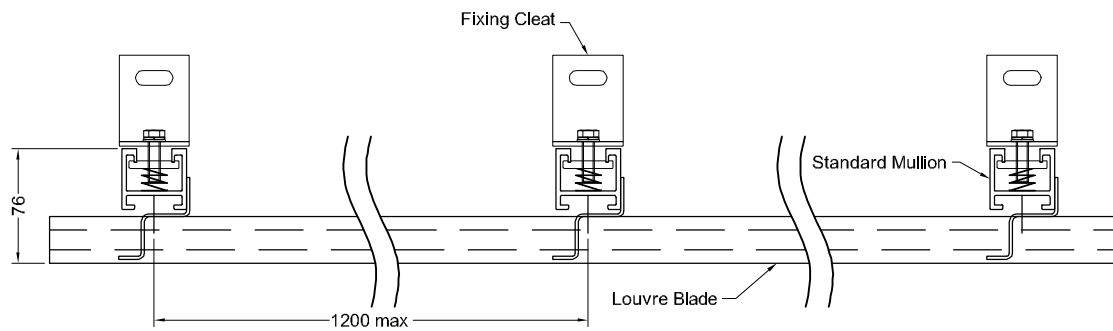

QEF - Galv Louvre
Plan Fixed to Standard Mullion

Specification

Manufacture & Reference: QEF Galv Screening Blade Louvre System, supplied and installed by QEF Ltd.
Tel: +353 (0)56 776 4910
Fax: +353 (0)56 776 1557 .

Description: 60mm Pitch 1.2mm Galv Pressed Metal ventilation Louvre with 30mm flat face, mounted on mullions fixed to structure with adjustable galvanised steel cleats.

Blade pitch: 60mm.

Material: Manufactured from 1.2mm Galvanised Steel.

Finish: Polyester powder coated to RAL or BS colour, in matt, satin or gloss finishes

Dimensions: All Louvres are bespoke to clients needs

Performance: Louvre decorative only.

Fixing: All structural support by main contractor

Accessories: Bird / insect mesh, blanking / insulated blanking plate to rear. Single / Double doors.



Commercial Centre
Dublin Road
Kilkenny

Tel: +353 (0)56 776 4910
Fax: +353 (0)56 776 1557
Website: www.qefltd.ie
Email: sales@qefltd.ie

Drawn	Date	Scale
RS	14.04.16	NTS
Drawn	Rev	
L/60 Galv/S/H		